

## Sample Approval Sheet

**Customer Name:** Quiwi srl

**Product Name:** 3.5x2.8x1.9mm Pure White SMD LED

**Model:** SLQTVB

**Date:** Oct.24, 2008

Prepared by	Checked by	Approved by	Marketing Dept.
Feiyu Liu	KH Chen	Landy Lan	Daisy Tsai

CUSTOMER CONFIRMATION		
Confirmed by	Checked by	Approved by

■Features

- High Luminous PLCC2 Top SMD LEDs
- 3.5x2.8x1.9mm Standard Directivity
- Superior Weather-resistance
- UV Resistant Epoxy
- Water Clear Type

■Applications

- Automotive Dashboard Lighting
- Small Area Illuminations
- Back Lighting
- Other Lighting
- 

■Outline Dimension

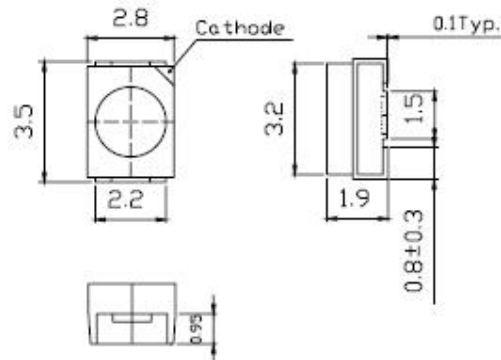

■Absolute Maximum Rating

(Ta=25°C)

Item	Symbol	Value	Unit
DC Forward Current	$I_F$	30	mA
Pulse Forward Current*	$I_{FP}$	100	mA
Reverse Voltage	$V_R$	5	V
Power Dissipation	$P_D$	108	mW
Operating Temperature	$T_{opr}$	-30 ~ +85	°C
Storage Temperature	$T_{stg}$	-40~ +100	°C
Lead Soldering Temperature	$T_{sol}$	260°C/5sec	-

\*Pulse width Max.10ms , Duty ratio max 1/10\*\*

■Directivity

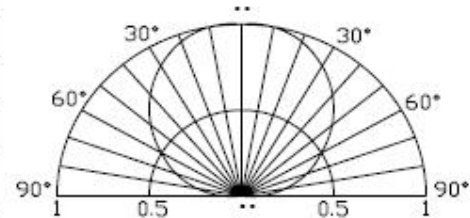

■Electrical -Optical Characteristics

(Ta=25°C)

Item	Symbol	Condition	Min.	Typ	Max.	Unit
DC Forward Voltage	$V_F$	$I_F=20mA$	2.9	3.1	3.6	V
DC Reverse Current	$I_R$	$V_R=5V$	-	-	10	μA
Luminous Intensity*	$I_v$	$I_F=20mA$	330	500	750	mcd
Chromaticity Coordinate*	x	$I_F=20mA$	0.28	0.30	0.33	
	y	$I_F=20mA$	0.27	0.31	0.34	
50% Power Angle	$2\theta_{1/2}$	$I_F=20mA$	-	120	-	deg

\*1 Tolerance of dominant wavelength is ±1nm

\*2 Tolerance of luminous intensity is ±15%

**InGaN LED**

**TYPICAL ELECTRICAL/OPTICAL CHARACTERISTIC CURVES**

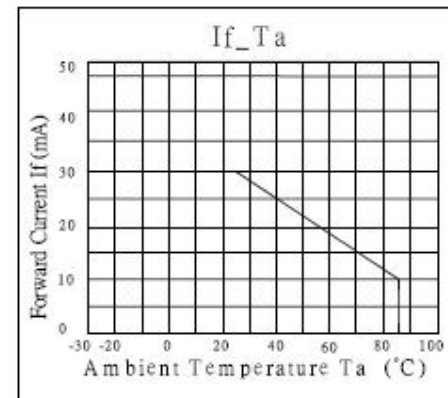
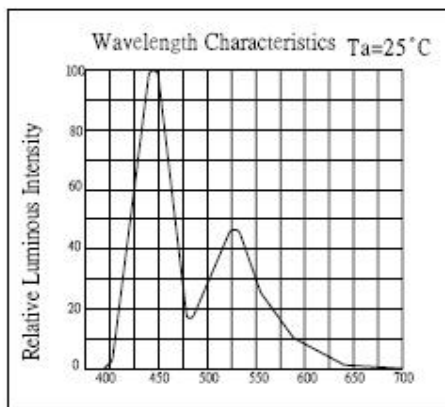
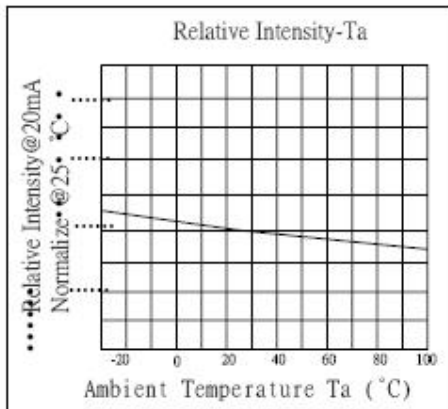
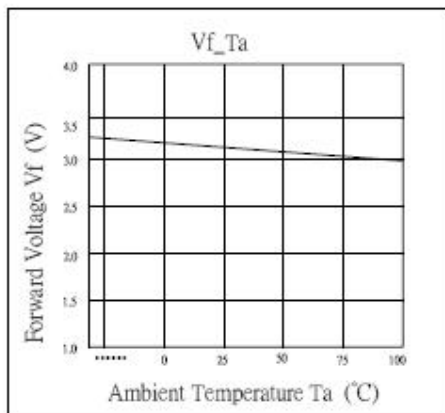
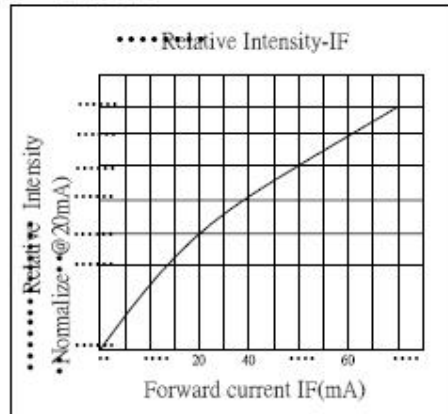
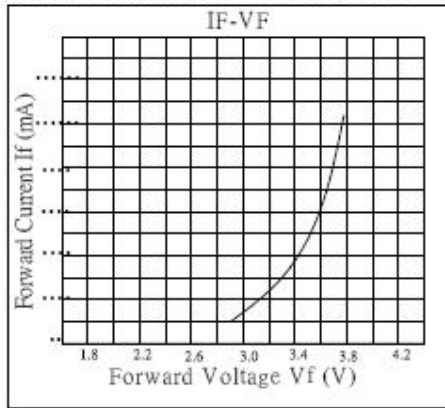

**RELIABILITY TEST REPORT**

CLASSIFICATION	TEST TIME	TEST CONDITON
ENDURANCE TEST	OPERATION LIFE	If: 20mA Ta:25±5 TEST TIME=1000HRS(-24HRS,+72HRS)
	HIGH TEMPERTURE HIGH HUMIDITY STORAGE	R.H:90~95% Ta:65±5°C TEST TIME=240HRS(+2HRS)
	HIGH TEMPERTURE STORAGE	Ta:105±5°C TEST TIME=500HRS(-24HRS,+48HRS)
	LOW TEMPERTURE STORAGE	Ta:-55±5°C TEST TIME=500HRS(-24HRS,+48HRS)
ENVIRONMENTAL TEST	TEMPERTURE CYCLING	105°C~25°C~55°C~25°C 60min 10min 60min 10min 20cycles
	THERMAL SHOCK	105°C~55°C 10min 10min 10cycles
	SOLDER RESISTANCE	Ta:260±5°C TEST TIME=10±1sec
	SOLDERABILITY	Ta:230±5°C TEST TIME=5±1sec

**JUDGMENT CRITERIA OF FALURE FOR THE RELIABILITY**

MEASURING ITME	SYMBOL	CONDITIONS	FAILURE
LUMINOUS INTENSITY	IV	IF=20mA	IV<0.5*INITIAL VALUE
FORWARD VOLTAGE	VF	IF=20mA	VF>1.2*INITIAL VALUE
REVERSE CURRENT	IR	Vr=5V	IR>2*SPEC

**OPERATION LIFE TEST LUMINANCE RATE CURVE**

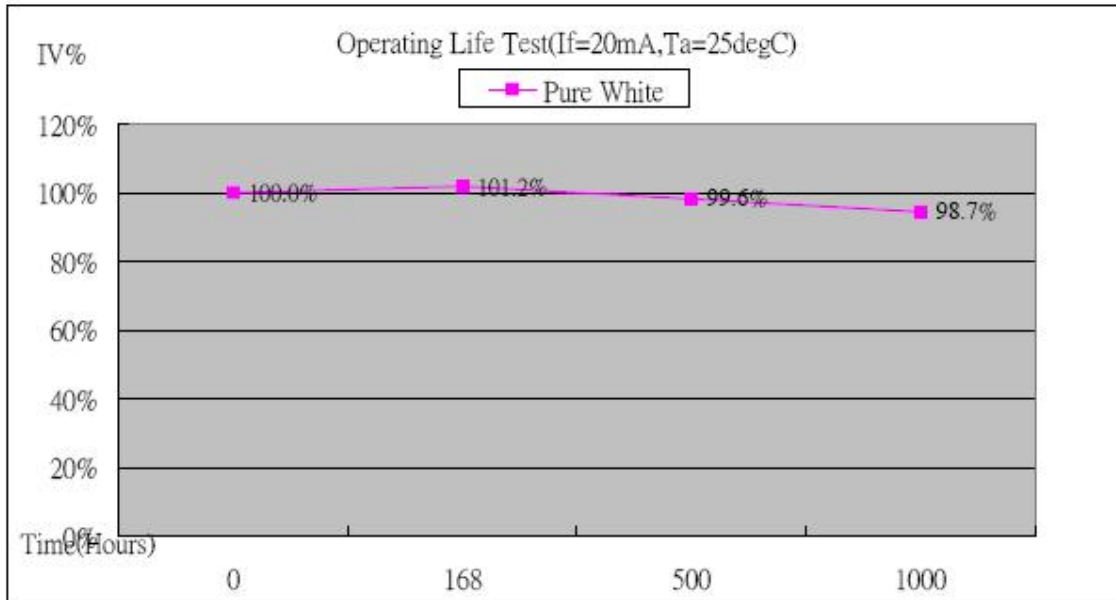

- \*Burn-in condition: 20mA
- \*Projection of Statistical Average Light Output Degradation Performance for LED Technology Extrapolated from OptoSupply QA Dept. Test Data.
- \*According to OptoSupply outgoing Packaged Products Specification
- \*MTBF:100,000hrs, 90% Confidence (A Failure is Any LED Which is Open, shorted or fails to Emit Light)
- \*The Projected Data is Base on The Feature of LED Itself Under Normal Operation Conditions.
- \*Any Improper Circuit Design or External Factors Might Cause a Different Result.

## Soldering Heat Reliability (DIP):

### 1. IR Reflow soldering Profile

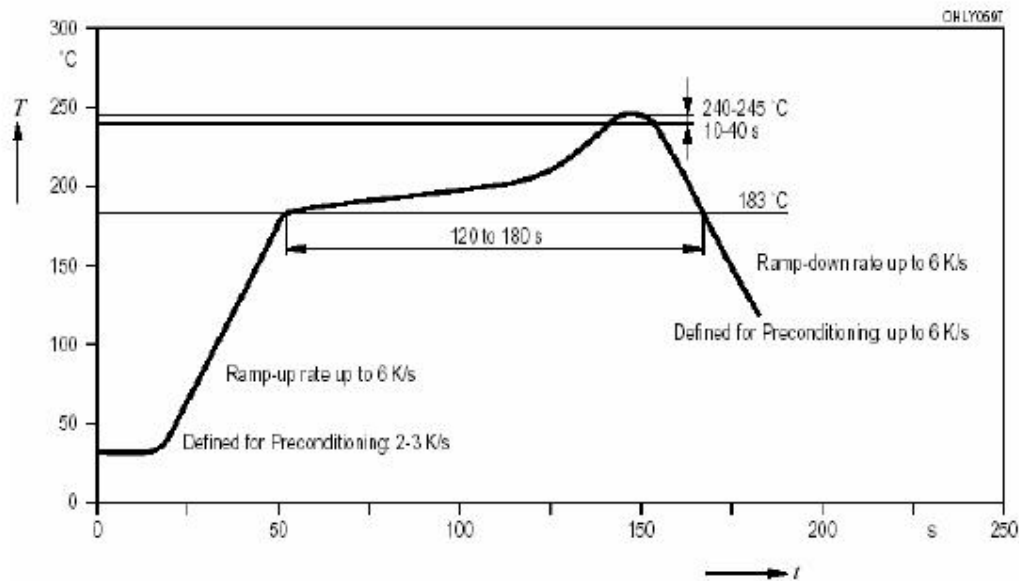

### 2. TTW Soldering:

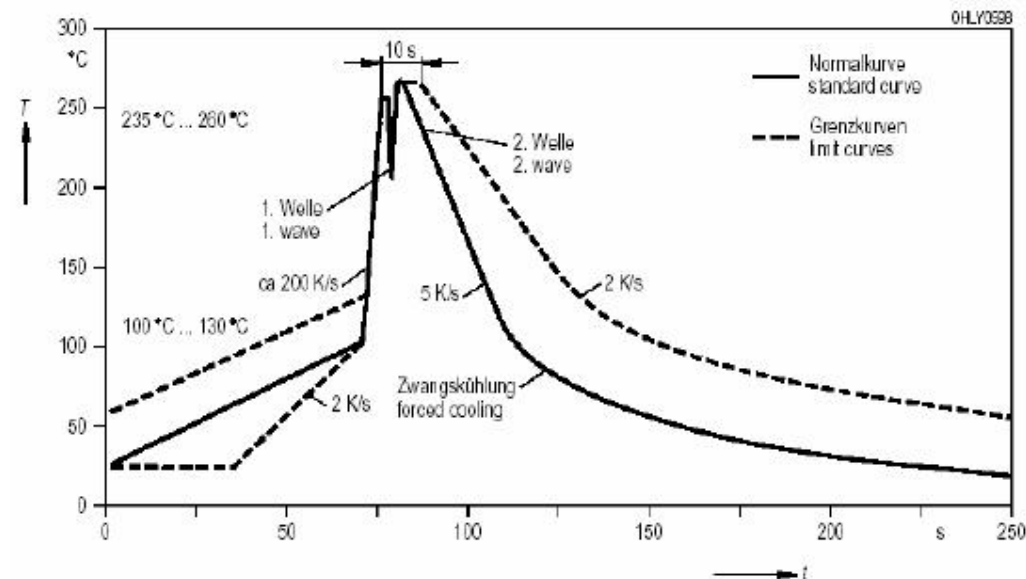

**PACKING**

**PART NUMBER FORMATION**

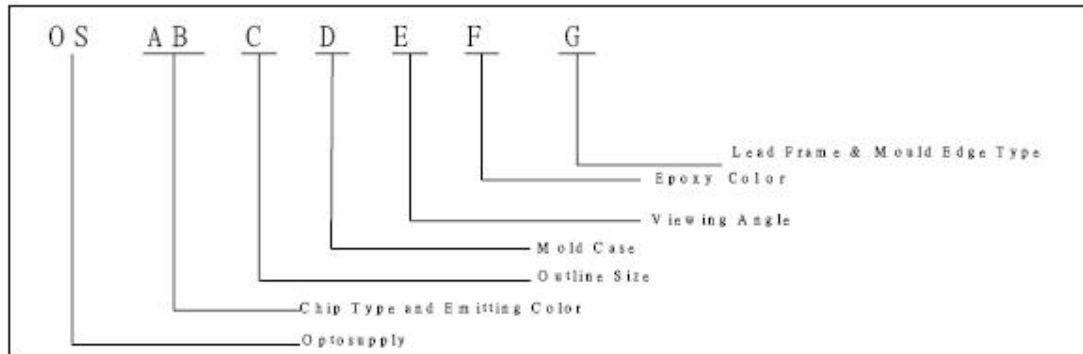

**PACKING DIMENTIONS**

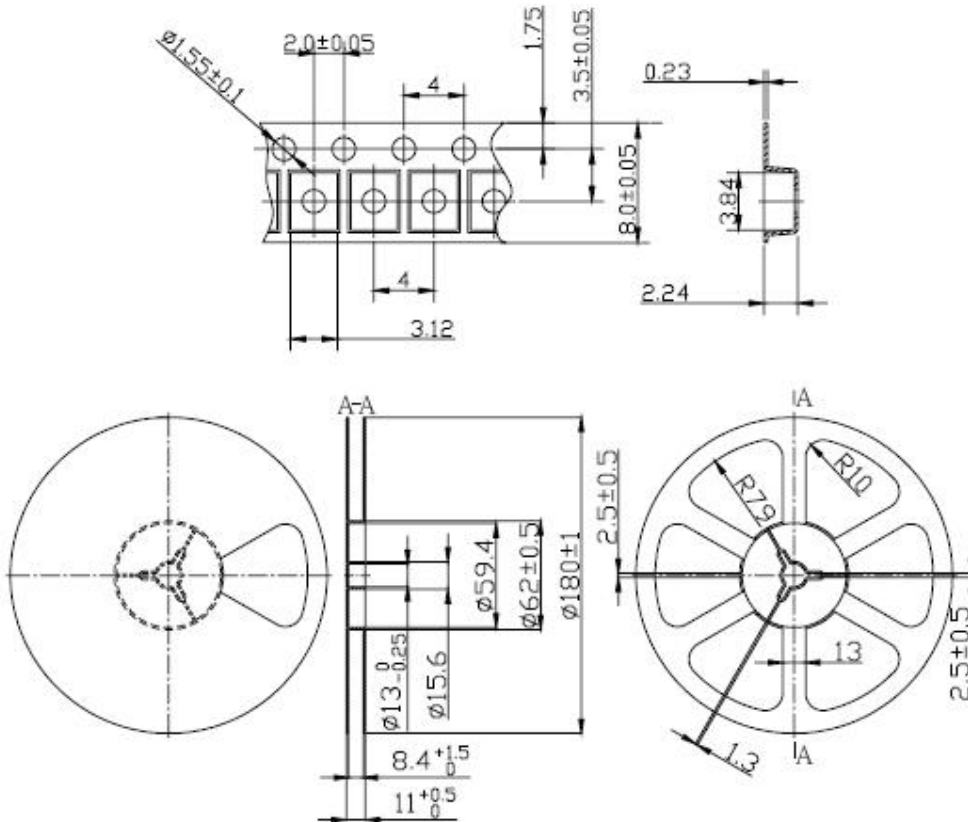

Notes:

1. Unit: mm
2. 2000pcs/Reel