

■ Features

- High Luminous LEDs
- 8mm Straw Standard Directivity
- Superior Weather-resistance
- UV Resistant Epoxy
- Water Clear Type

■ Applications

- Traffic Signal
- Backlighting
- Signal and channel letter
- Other Lighting

■ Outline Dimension

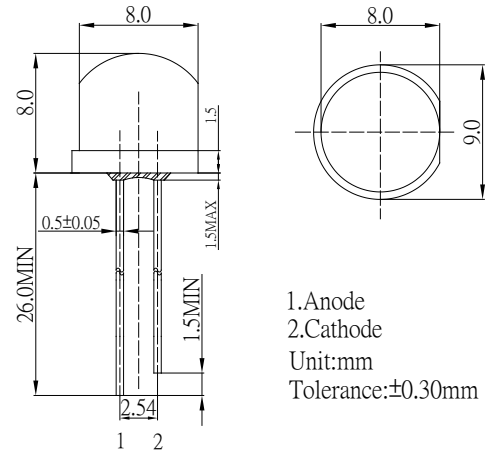

■ Absolute Maximum Rating (Ta=25°C)

| Item | Symbol | Value | Unit |
|----------------------------|-----------|-------------|------|
| DC Forward Current | I_F | 50 | mA |
| Pulse Forward Current* | I_{FP} | 120 | mA |
| Reverse Voltage | V_R | 5 | V |
| Power Dissipation | P_D | 130 | mW |
| Operating Temperature | T_{opr} | -30 ~ +85 | °C |
| Storage Temperature | T_{stg} | -40 ~ +100 | °C |
| Lead Soldering Temperature | T_{sol} | 260°C/ 5sec | - |

*Pulse width Max.10ms Duty ratio max 1/10

■ Directivity

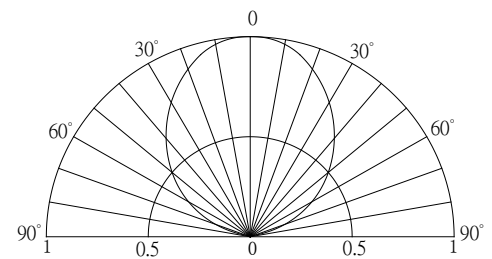

■ Electrical -Optical Characteristics (Ta=25°C)

| Item | Symbol | Condition | Min. | Typ. | Max. | Unit |
|---------------------|-----------------|------------|------|------|------|------|
| DC Forward Voltage | V_F | $I_F=20mA$ | 1.8 | 2.1 | 2.6 | V |
| DC Reverse Current | I_R | $V_R=5V$ | - | - | 10 | μA |
| Domi. Wavelength* | λ_D | $I_F=20mA$ | 620 | 625 | 630 | nm |
| Luminous Intensity* | I_v | $I_F=20mA$ | 2180 | 3000 | - | mcd |
| 50% Power Angle | $2\theta_{1/2}$ | $I_F=20mA$ | - | 100 | - | deg |

*1 Tolerance of dominant wavelength is ±1nm

*2 Tolerance of luminous intensity is ±15%

■ Maximum Forward Current

