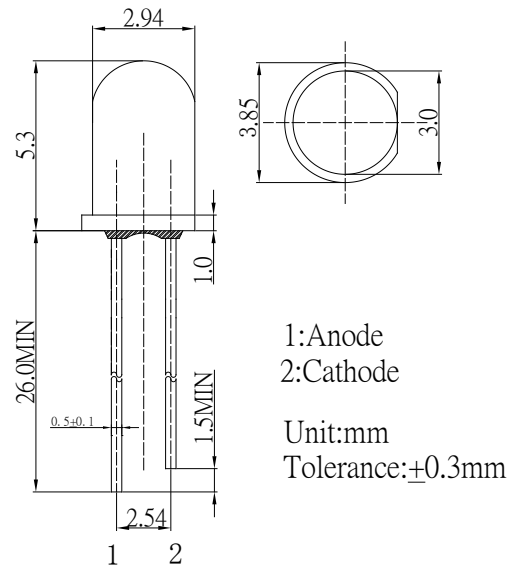

■Features

- 3ø Standard Directivity
- Superior Weather-resistance
- UV Resistant Epoxy
- Water Clear Type
- RoHS Compliant

■Applications

- General Purpose Indicators
- Small Area Illuminations
- Back Lighting

■Outline Dimension

■Absolute Maximum Rating

(Ta=25 °C)

Item	Symbol	Value	Unit
DC Forward Current	I_F	30	mA
Pulse Forward Current*	I_{FP}	100	mA
Reverse Voltage	V_R	5	V
Power Dissipation	P_D	120	mW
Operating Temperature	T_{opr}	-30~ +80	°C
Storage Temperature	T_{stg}	-30 ~+100	°C
Lead Soldering Temperature	T_{sol}	260°C3sec	-

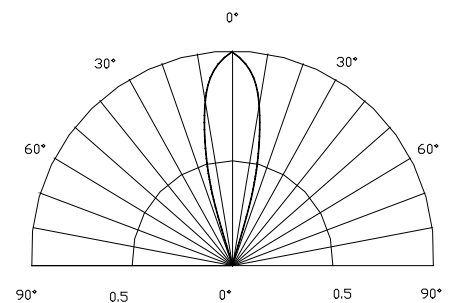
*Pulse width Max.10ms Duty ratio max 1/10

■Directivity

■Electrical -Optical Characteristics

(Ta=25 °C)

Item	Symbol	Condition	Min.	Typ.	Max.	Unit
DC Forward Voltage	V_F	$I_F=20mA$	2.8	3.4	4.0	V
DC Reverse Current	I_R	$V_R=5V$		-	10	μA
Luminous Intensity	I_v	$I_F=20mA$	5800	7000	8400	mcd
Chromaticity Coordinate*	x	$I_F=20mA$	0.27	0.30	0.33	
	y	$I_F=20mA$	0.28	0.31	0.34	
50% Power Angle	$2\theta_{1/2}$	$I_F=20mA$	-	30	-	deg

*Please refer to CIE 1931 chromaticity diagram.