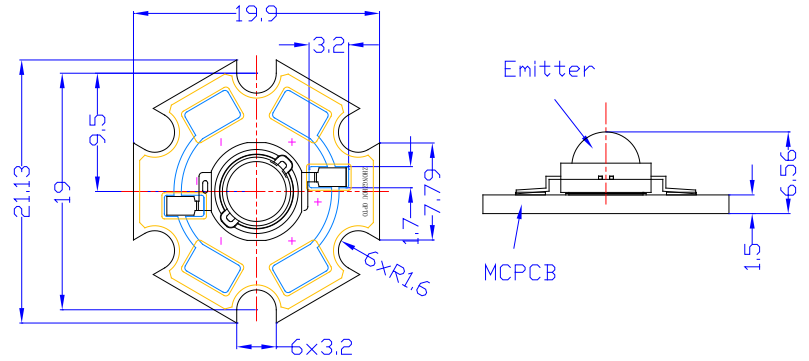

■Features

- Highest Luminous Flux
- Super energy efficiency
- Long Lifetime Operation
- Built-in Zener Diode For ESD Protection

■Outline Dimension

Unit:mm
Tolerances are for reference only

■Applications

- Read lights (car, bus, aircraft)
- Portable (flashlight, bicycle)
- Bollards / Security / Garden
- Traffic signaling / Beacons
- In door / Out door Commercial lights
- Automotive Ext

■Absolute Maximum Rating

(Ta=25°C)

Item	Symbol	Value	Unit
DC Forward Current	I _F	400	mA
Pulse Forward Current*	I _{FP}	500	mA
Reverse Voltage	V _R	5	V
Power Dissipation	P _D	1600	mW
Operating Temperature	Topr	-30 ~ +85	°C
Storage Temperature	Tstg	-40~ +100	°C
Lead Soldering Temperature	Tsol	260°C5sec	-

*Pulse width Max.10ms Duty ratio max 1/10

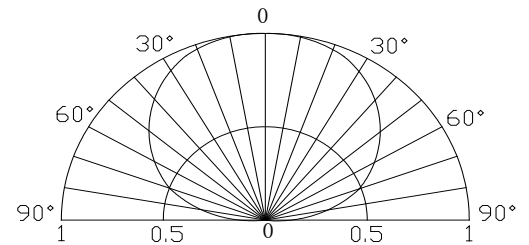
■Directivity

■Electrical -Optical Characteristics

(Ta=25°C)

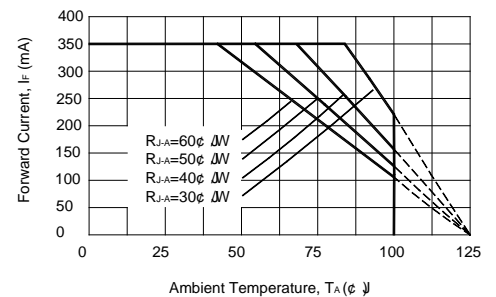
Item	Symbol	Condition	Min.	Typ.	Max.	Unit
DC Forward Voltage	V _F	I _F =350mA	3.0	3.3	4.0	V
DC Reverse Current	I _R	V _R =5V	-	-	10	μA
Domi. Wavelength	λ _D	I _F =350mA	455	460	465	nm
Luminous Flux	Φ _v	I _F =350mA	15	20	-	lm
50% Power Angle	2θ _{1/2}	I _F =350mA	-	140	-	deg

■Forward Operating Current (DC)

Note: Don't drive at rated current more than 5s without heat sink for Xeon 1 emitter series.

■ Soldering Heat Reliability :

Reflow soldering Profile

- Reflow soldering should not be done more than two times.
- When soldering, do not put stress on the LEDs during heating.
- After soldering, do not warp the circuit board.
- Repairing should not be done after the LEDs have been soldered. When repairing is unavoidable, a double-head soldering iron should be used. It should be confirmed beforehand whether the **characteristics of the LEDs will or will not be damaged by repairing.**

Solder
Average ramp-up rate = 3°C/sec. max.
Preheat temperature: 150°~180°C
Preheat time = 120 sec. max.
Ramp-down rate = 6°C/sec. max.
Peak temperature = 220°C max.
Time within 3°C of actual peak temperature = 25 sec. max.
Duration above 200°C is 40 sec. max.

